

RoHS COMPLIANT

F	CHANGE DRAWING	2013/05/03	DESCRIPTION CONTROL				DESCRIPTION CONTROL			
F-1	CHANGE DRAWING	2013/05/10	REV	DESC	DATE	APP	REV	DESC	DATE	APP
G	CHANGE DRAWING	2013/06/25	D	ADD LABEL SPEC	2013/04/25		A	FIRST RELEASE	2013/03/22	
			E	CHANGE CARTON SPEC	2013/04/29		B	CHANGE DRAW	2013/03/27	
							C	CHANGE LENGTH	2013/04/09	

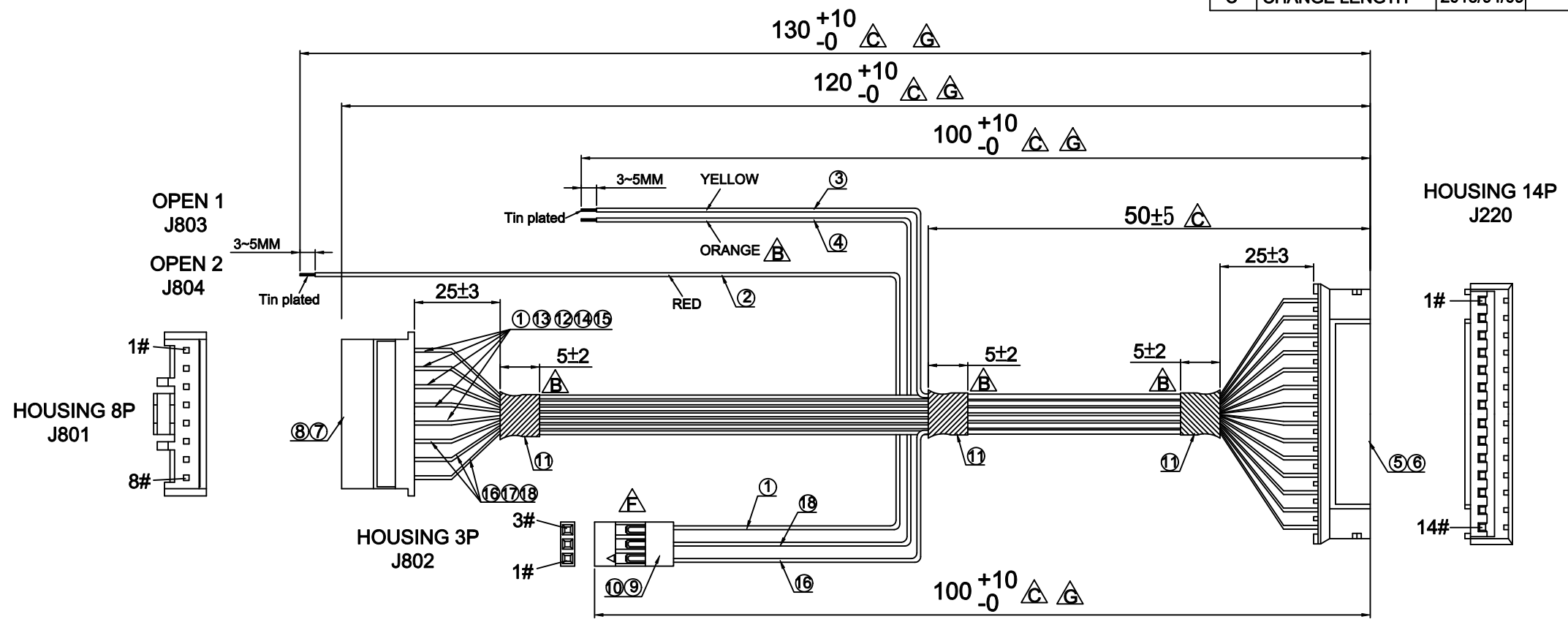

NOTES:

- PIN ASSIGNMENT SEE TO WIRE LIST.
- ELECTRICAL TEST CONDITION:
 - 100% OPEN, SHORT & MISWIRE TEST,
 - INSULATOR RESISTANCE: 20 Mohm MIN. DC 300V 0.01sec.
 - CONTACT RESISTANCE: 1ohm MAX.

UNIT	mm	Projection			Seconn International Enterprise Co., Ltd.
DRAWN	<i>Huang shenggen</i>	SCALE	1:1	TITLE	
CHECK, BY		REV	G	HOUSING 14PIN/HOUSING 8PIN+3PIN	
APP, BY		DATE	2013/03/22	TOLERANCES	
DWG NO.	SE-S-0072	X.= ±	.X= ±	.XX= ±	.XXX= ±
PART NO.	0411-000-001	SHEET	1/3	SIZE	A4

RoHS COMPLIANT

F	CHANGE DRAWING	2013/05/03	DESCRIPTION CONTROL				DESCRIPTION CONTROL			
F-1	CHANGE DRAWING	2013/05/10	REV	DESC	DATE	APP	REV	DESC	DATE	APP
G	CHANGE DRAWING	2013/06/25	D	ADD LABEL SPEC	2013/04/25		A	FIRST RELEASE	2013/03/22	
			E	CHANGE CARTON SPEC	2013/04/29		B	CHANGE DRAW	2013/03/27	
							C	CHANGE LENGTH	2013/04/09	

PIN ASSIGNMENT

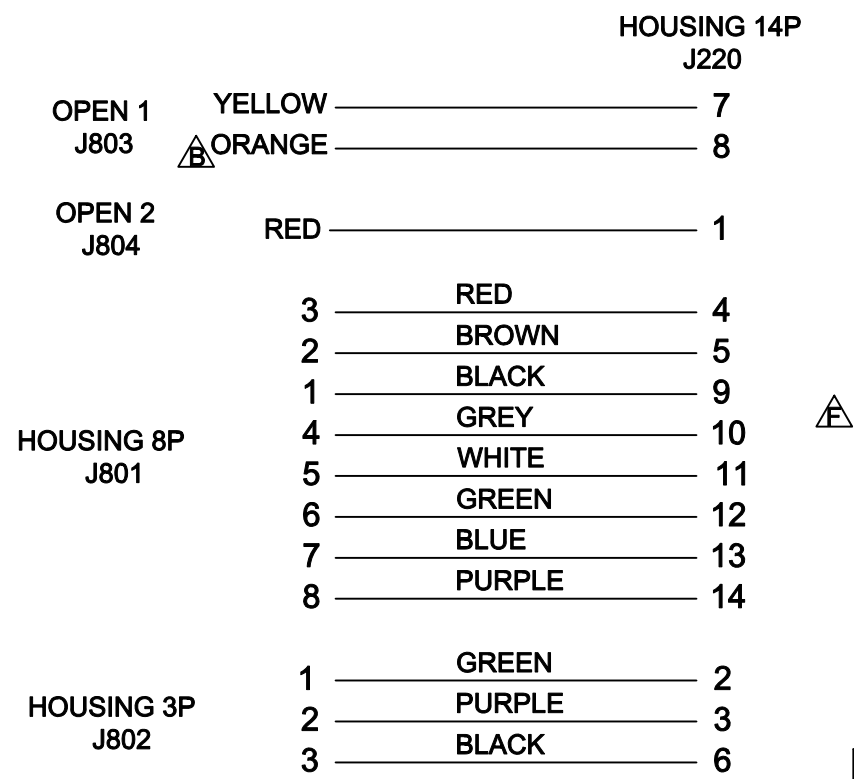

18	2	F0131	UL1007 24AWG PURPLE JUMP WIRE.
17	1	F0130	UL1007 24AWG BLUE WIRE.
16	2	F0051	UL1007 24AWG GREEN JUMP WIRE.
15	1	F0133	UL1007 24AWG WHITE JUMP WIRE.
14	1	F0132	UL1007 24AWG GREY JUMP WIRE.
13	1	F0107	UL1007 24AWG BROWN JUMP WIRE.
12	1	F0106	UL1007 24AWG RED JUMP WIRE.
11	3		BLACK HEAT SHRINK TUBE.
10	3	B0324	TERMINAL:PITCH2.54MM JS-1108-TB(G).
9	1		HOUSING:PITCH2.54MM 3PIN JS-1108-03.
8	8		TERMINAL:PITCH2.0MM JST SPHD-001T-P0.5.
7	1		HOUSING:PITCH2.0MM 8PIN JST PAP-08V-S.
6	14		TERMINAL:PITCH2.0MM JST SPH-002T-P0.5S.
5	1		HOUSING:PITCH2.0MM 14PIN JST PHR-14.
4	1		UL1007 22AWG ORANGE JUMP WIRE.
3	1	F0072	UL1007 22AWG YELLOW JUMP WIRE.
2	1	F0070	UL1007 22AWG RED JUMP WIRE.
1	2	F0011	UL1007 24AWG BLACK JUMP WIRE.
ITEM	QTY	PART NUMBER	DESCRIPTION

UNIT	mm	Projection			Seconn International Enterprise Co., Ltd.	
DRAWN	<i>Huang shenggen</i>	SCALE	1:1	TITLE		
CHECK, BY		REV	G	HOUSING 14PIN/HOUSING 8PIN+3PIN		
APP, BY		DATE	2013/03/22	TOLERANCES		
DWG NO.	SE-S-0072		X.= ±	.X= ±	.XX= ±	.XXX= ±
PART NO.	0411-000-001		SHEET	2/3	SIZE	A4

RoHS COMPLIANT

F	CHANGE DRAWING	2013/05/03
F-1	CHANGE DRAWING	2013/05/10
G	CHANGE DRAWING	2013/06/25

DESCRIPTION CONTROL			
REV	DESC	DATE	APP
D	ADD LABEL SPEC	2013/04/25	
E	CHANGE CARTON SPEC	2013/04/29	

DESCRIPTION CONTROL			
REV	DESC	DATE	APP
A	FIRST RELEASE	2013/03/22	
B	CHANGE DRAW	2013/03/27	
C	CHANGE LENGTH	2013/04/09	

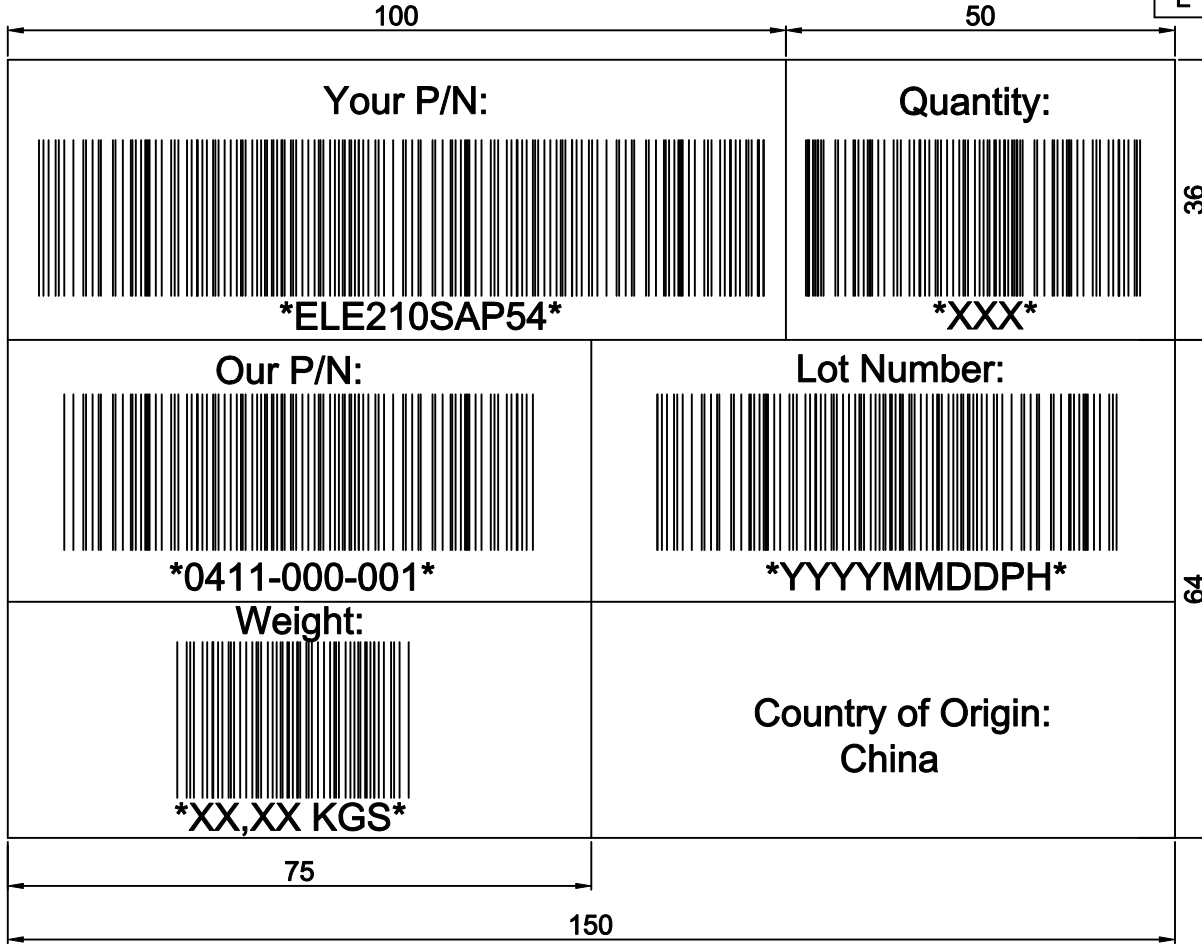

CARTON LABEL

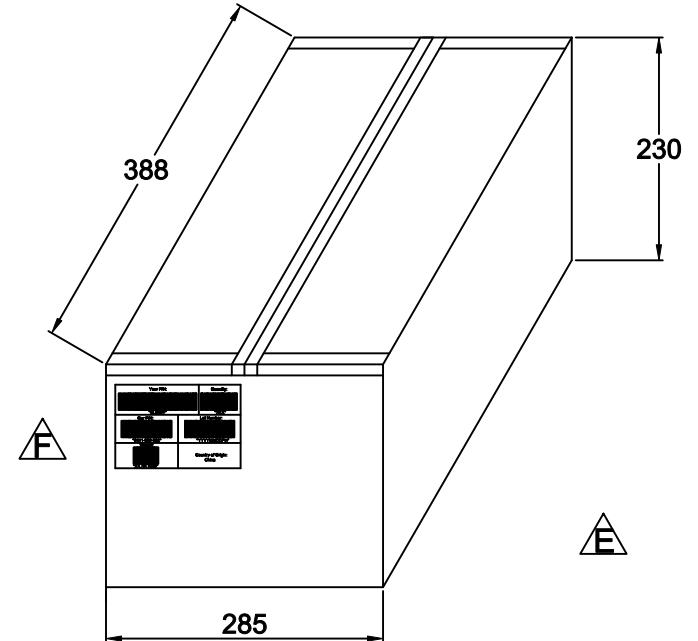

CARTON

Font type:Ariel 5mm
Barcode type:code 3 of 9
Barcode size:20mm
(Except"Weight"10mm)

Lot number:YYYYMMDDH
YYYY=year
MM=month
DD=day
P=product with this production date,
First P/N="A",next P/N=B,etc.*
H:Lot size,First 10K="A",next 10K="B",
etc of this P/N.

UNIT	mm	Projection			Seconn International Enterprise Co., Ltd.
DRAWN	<i>Huang shenggen</i>	SCALE	1:1	TITLE	
CHECK, BY		REV	G	HOUSING 14PIN/HOUSING 8PIN+3PIN	
APP, BY		DATE	2013/04/25	TOLERANCES	
DWG NO.	SE-S-0072	X.= ±	.X= ±	.XX= ±	.XXX= ±
PART NO.	0411-000-001	SHEET	3/3	SIZE	A4